

TERMINATED VIEW

- ⚠ MOLDED PARTS: POLYESTER, BLACK, UL RATED 94V-0.
- ⚠ CONTACTS: PHOSPHOR BRONZE PER QQ-B-750.
- ⚠ CONTACTS: PLATED WITH 0.38μm [.000015] MIN GOLD IN LOCALIZED GOLD PLATE AREA, 1.27μm [.000050] MIN TIN ON TERMINATION END, ALL OVER 1.27μm [.000050] MIN NICKEL ON ENTIRE CONTACT.  
OR  
GOLD FLASH OVER PALLADIUM-NICKEL PLATE 0.38μm [.000015] MIN TOTAL IN LOCALIZED GOLD PLATE AREA, 1.27μm [.000050] MIN TIN ON TERMINATION END, ALL OVER 1.27μm [.000050] MIN NICKEL ON ENTIRE CONTACT.

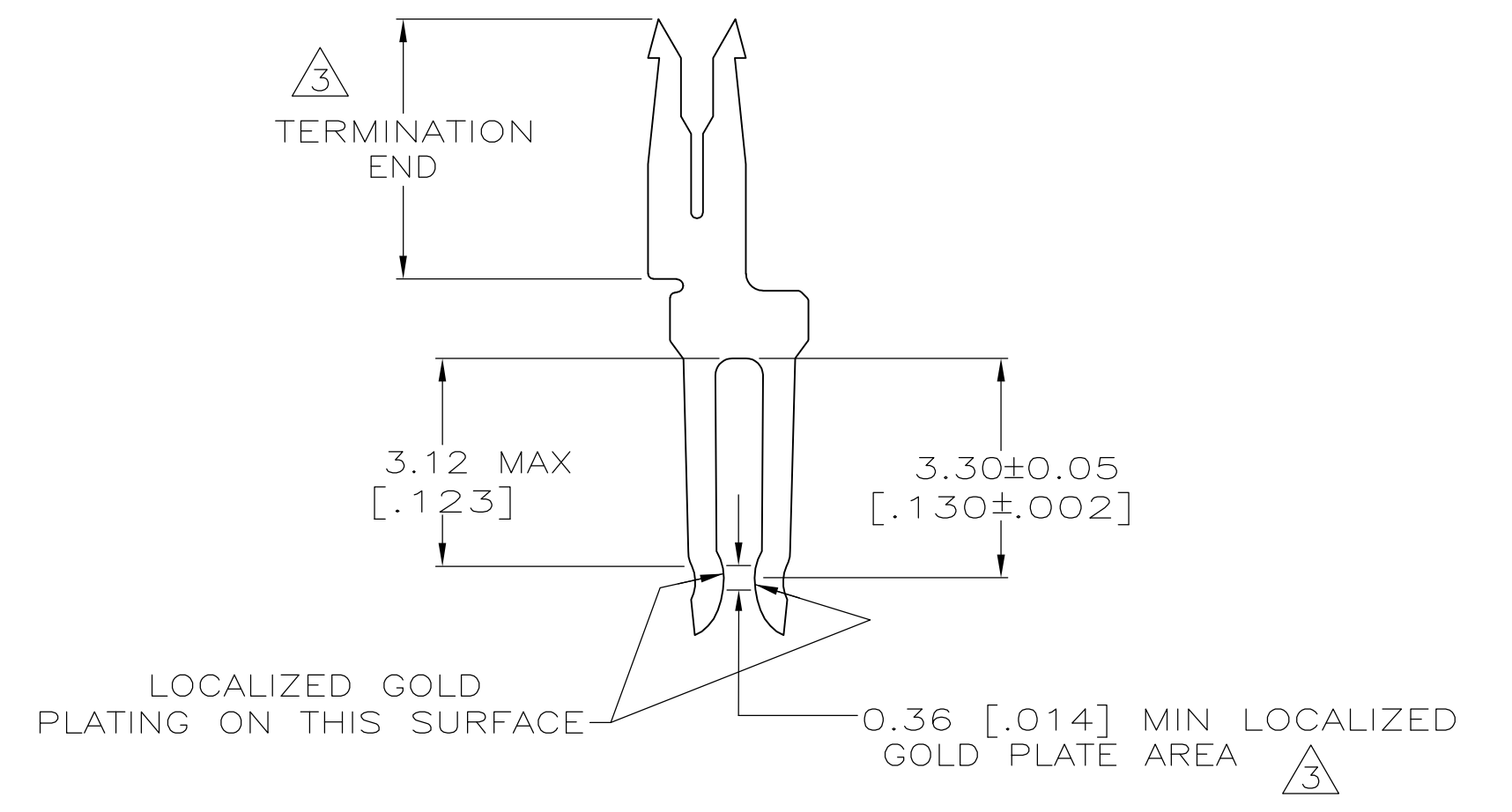

DETAIL Z  
SCALE 10:1  
TYPICAL

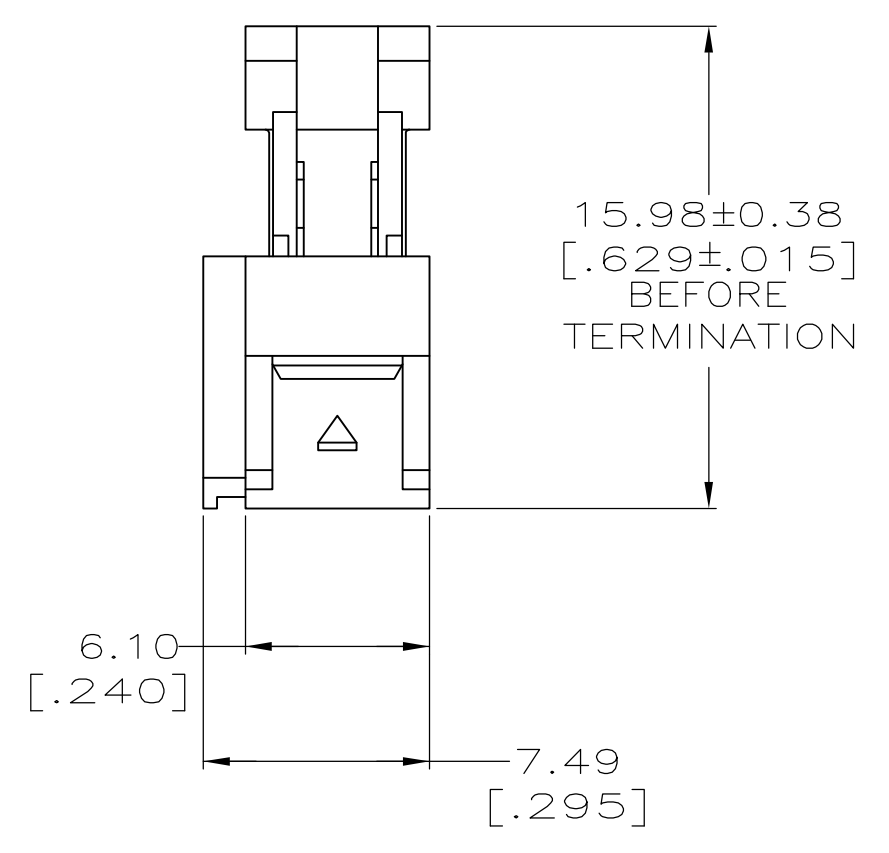
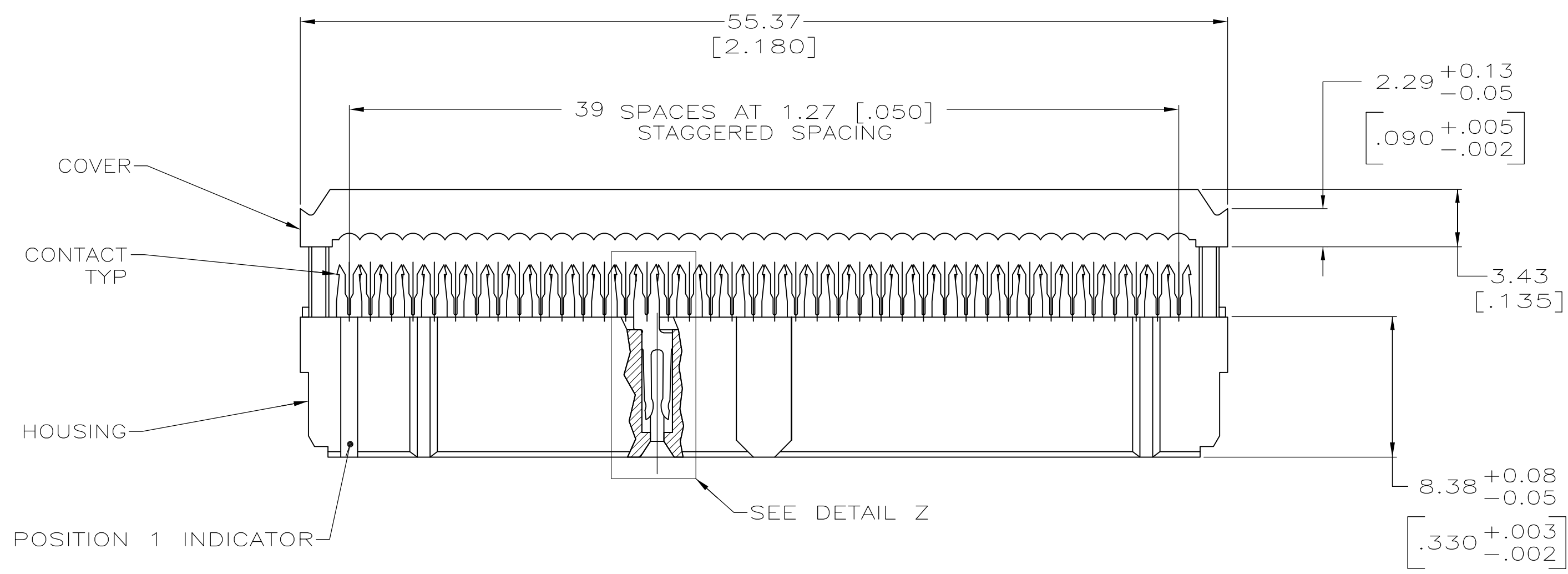
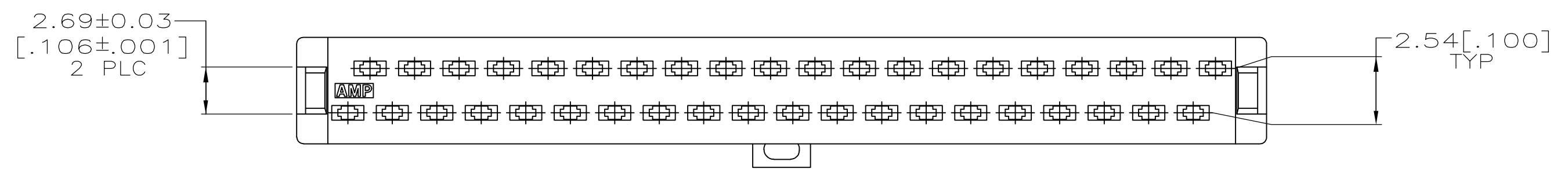
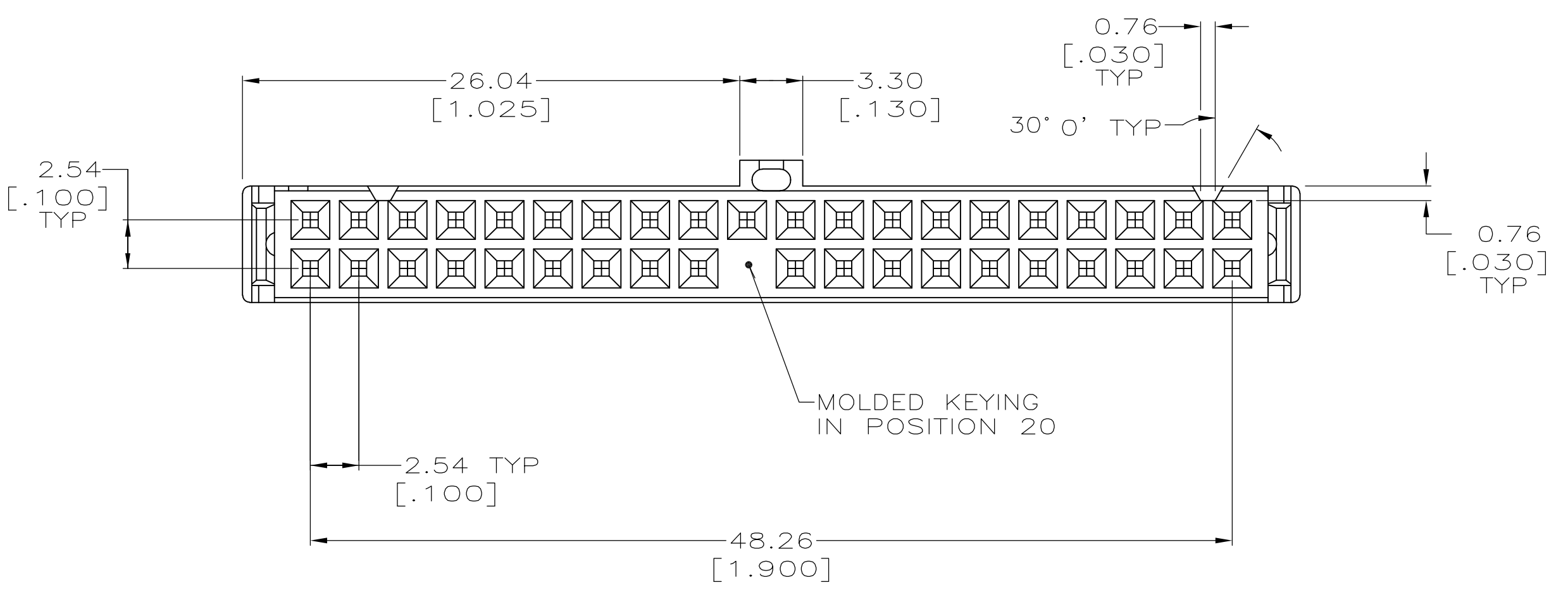

40	5111877-1
NO OF POSN	PART NUMBER

THIS DRAWING IS A CONTROLLED DOCUMENT.		DRN: R. MCMMASTER 10JUNE04	Tyco Electronics Corporation Harrisburg, PA 17105-3608	
DIMENSIONS: mm [INCHES]		CHK: R. STONE 10JUNE04	NAME: M. WALMSLEY 10JUNE04	
TOLERANCES UNLESS OTHERWISE SPECIFIED:		PRODUCT SPEC: 108-40000	RECEPTACLE KIT, FULL COVER, CENTER & MILITARY POLARIZATION, NOVO, AMP-LATCH	
0 PLC ± -		APPLICATION SPEC: 114-40005	RESTRICTED TO: -	
1 PLC ± -		SIZE: A1	CAGE CODE: 00779	
2 PLC ± 0.13 [.005]		SCALE: 4:1	SHEET: 1 OF 1	
3 PLC ± -		REV: B	REV: -	
4 PLC ± -		CUSTOMER DRAWING		
ANGLES ± 0°30'				
FINISH: SEE NOTES				